

# **SM Series Bell-202, Bell-202T, V.23 Modems**

## **Configuration and User's Guide**

**Version 1.10**

Applied Systems Engineering, Inc.  
1671 Dell Avenue, Suite 200  
Campbell, California 95008  
USA  
E-mail: [support@ase-systems.com](mailto:support@ase-systems.com)  
Tel: (408) 364-0500  
Fax: (408) 364-0550



---

Property of Applied Systems Engineering, Inc.

This document and its associated distribution media contain proprietary information of Applied Systems Engineering, Inc. and may not be used, copied, or distributed in any form without the written permission of Applied Systems Engineering, Inc.

Copies of this documentation may be made for internal use by the legally licensed owner only.

© 2002 Applied Systems Engineering, Inc. All rights reserved

---

## Table of Contents

<b>FEATURES.....</b>	<b>1</b>
<b>PACKAGING .....</b>	<b>1</b>
<b>SWITCH SETTINGS.....</b>	<b>2</b>
<b>JUMPER SETTINGS FOR BOX MOUNT (5006) MODEM (REV C).....</b>	<b>3</b>
<b>JUMPER SETTINGS FOR RACK MOUNT (5008) MODEM (REV C).....</b>	<b>4</b>
<b>POWER CONNECTION .....</b>	<b>5</b>
<b>RJ-11 CABLING .....</b>	<b>5</b>
<b>RS-232 CABLING .....</b>	<b>5</b>
<b>COMMON PROBLEMS AND SOLUTIONS .....</b>	<b>5</b>
<b>PRODUCT CODES.....</b>	<b>6</b>
<b>DIAGRAM: RACK MOUNT MODEM BOARD .....</b>	<b>7</b>
<b>DIAGRAM: BOX MOUNT MODEM BOARD .....</b>	<b>8</b>
<b>DIAGRAM: RACK MOUNT ENCLOSURE BACKPLANE .....</b>	<b>9</b>

## **Features**

### **Power**

- 5 VDC or 12 to 160 VDC, draws less than 500 mw
- Power cable can be removed/inserted with power on
- "Hot Card Swap" on rack mount configuration

### **Timings**

- Carrier detect on delay: 2 to 30 msec.
- RTS/CTS delay: 0 to 254 msec. or constant CTS

### **Levels**

- Transmit Gain: 0 to -31 dB, switch selectable, 1dB increments
- Receiver Gain: -35 or -45 dB, switch selectable

### **Isolation**

- 1,500 VAC Telco
- 1,800 VAC Power Supply

### **LEDs**

- LEDs for transmit (TD) and receive (RD) data, RTS, CTS, carrier detect (CD), and power

### **Connections**

- Analog side via 4-wire RJ-11
- Digital side via DB-25 RS-232

### **Other**

- 2-wire or 4-wire (2-wire with optional 156 msec. receiver squelch)
- Constant or switched carrier
- 900Hz soft carrier turn-off

## **Packaging**

The modem dimension is based on a VME form-factor PC card (100 x 160mm) that can be mounted in an optional metal box (Model 5006), inserted into a VME-style rack (Model 5008), or mounted in a customer enclosure (Model 5006) with 4 4-40 screws. The metal box dimensions are 7.35 x 4.14 x 1.42" (187 x 105 x 36 mm) and include flanges with 4 mounting holes. For the rack mount version, power is provided through the backplane connector. For the Model 5006, power connection is via a 3-position terminal block.

### Switch Settings

- Settings Apply to Both Rack Mount (5008) and Box Mount (5006) Modem
- ***Bold Italics*** indicates factory settings

Switch	Usage	Notes	Position	Value if ON
SW1	Transmit gain	<ul style="list-style-type: none"> <li>• 0 to -31 dB</li> <li>• Add values for all switches in the ON position and add 0 to sum of switch values if <b>JP7</b> is installed and add -16 if <b>JP7</b> is removed.</li> </ul>	1	-1 dB
			2	-2 dB
			3	-4 dB
			4	-8 dB
<i>JP7</i>		<i>JP7 (See Jumper Settings)</i>	<i>installed</i>	
SW3	CD On Delay	<ul style="list-style-type: none"> <li>• Delay in setting RS-232 "CD" signal after carrier is detected, 2 to 30 milliseconds</li> <li>• Add values for all switches in the ON position</li> <li>• At least one switch must be ON</li> </ul>	1	2 msec
			2	4 msec
			<b>3</b>	<b>8 msec</b>
			4	16 msec
	900Hz soft-carrier turn-off	<ul style="list-style-type: none"> <li>• Soft-carrier turnoff duration, 1 to 15 milliseconds</li> <li>• Add values for all switches in the ON position.</li> <li>• At least one switch must be ON</li> </ul>	5	1 msec
			<b>6</b>	<b>2 msec</b>
			7	4 msec
			8	8 msec
SW4	RTS/CTS	<ul style="list-style-type: none"> <li>• Delay between requesting RTS and granting CTS, 0 to 254 milliseconds or constant</li> <li>• If switch 1 is OFF, add values for all switches (2 to 8) in ON position.</li> <li>• If all switches are OFF, CTS is constantly enabled</li> </ul>	1	0 msec
			2	2 msec
			<b>3</b>	<b>4 msec</b>
			4	8 msec
			<b>5</b>	<b>16 msec</b>
			6	32 msec
			7	64 msec
			8	128 msec

## Jumper Settings for Box Mount (5006) Modem (Rev E)

- ***Bold Italics*** indicates factory settings

Jumper	Usage	Notes	Jumper	Meaning
JP1	DTR/DSR	<ul style="list-style-type: none"> <li>• Uses DTR as “clear-to-send” signal, instead of CTS</li> <li>• Uses DSR as “request-to-send” signal instead of RTS</li> <li>• Normal mode (RTS/CTS) has no jumpers installed</li> </ul>	1-2	DTR
			3-4	DSR
JP2	Receiver gain	<ul style="list-style-type: none"> <li>• Sets receiver gain to -35 or -45 dB</li> <li>• Exactly one jumper must be installed</li> </ul>	1-2	-45 dB
			<b><i>3-4</i></b>	<b><i>-35 dB</i></b>
JP3	Receiver squelch	<ul style="list-style-type: none"> <li>• For half duplex mode, adds 156 millisecond delay between end of transmitted message and enabling receiver</li> <li>• Receiver constantly enabled if not installed</li> </ul>	1-2	156 msec
JP4	2W/4W	<ul style="list-style-type: none"> <li>• Selects 2-wire (half duplex) or 4-wire (full-duplex) operation</li> <li>• Exactly 2 jumpers must be installed</li> </ul>	1-2	2-wire
			3-4	
			<b><i>5-6</i></b>	<b><i>4-wire</i></b>
			<b><i>7-8</i></b>	
JP5	Carrier	<ul style="list-style-type: none"> <li>• Selects switched or constant carrier</li> <li>• Remove jumper for switched carrier</li> </ul>	1-2	<b><i>Removed</i></b>
JP6	900Hz soft carrier turn-off	<ul style="list-style-type: none"> <li>• Installed if 900Hz-carrier turn-off is not required.</li> <li>• Removed if 900Hz-carrier turn-off is required.</li> <li>• Note: Must be installed for V.23 CCITT operation</li> </ul>	<b><i>1-2</i></b>	<b><i>Installed</i></b>
JP7	Transmit level range selection	<ul style="list-style-type: none"> <li>• If installed, SW1 settings interpreted as 0 to -15 dB</li> <li>• If removed, SW1 settings interpreted as -16 to -31 dB</li> </ul>	<b><i>1-2</i></b>	<b><i>Installed</i></b>
JP8	Power Supply	<ul style="list-style-type: none"> <li>• If <b><i>1-3</i></b> and <b><i>2-4</i></b>, input power must be regulated 5 VDC</li> <li>• If <b><i>3-5</i></b> and <b><i>4-6</i></b>, input power can be 12 to 160 VDC</li> </ul>	1-3	5V
			2-4	
			<b><i>3-5</i></b>	<b><i>12-160 V</i></b>
			<b><i>4-6</i></b>	
JP9	Reserved	<ul style="list-style-type: none"> <li>• These jumpers are factory installed and must not be altered after shipment.</li> </ul>	<b><i>3-5</i></b>	<b><i>Installed</i></b>
			<b><i>4-6</i></b>	
JP10	Earth	<ul style="list-style-type: none"> <li>• Jumper inserted connects (-) power input to (S) shield on terminal block</li> </ul>	1-2	<b><i>Removed</i></b>

## Jumper Settings for Rack Mount (5008) Modem (Rev A)

- *Bold Italics indicates factory settings*

Jumper	Usage	Notes	Jumper	Meaning
JP1	DTR/DSR	<ul style="list-style-type: none"> <li>• Uses DTR as “clear-to-send” signal, instead of CTS</li> <li>• Uses DSR as “request-to-send” signal instead of RTS</li> <li>• Normal mode (RTS/CTS) has no jumpers installed</li> </ul>	1-2	DSR
			3-4	DTR
JP2	Receiver gain	<ul style="list-style-type: none"> <li>• Sets receiver gain to -35 or -45 dB</li> <li>• Exactly one jumper must be installed</li> </ul>	1-2	-45 dB
			<b>3-4</b>	<b>-35 dB</b>
JP3	Receiver squelch	<ul style="list-style-type: none"> <li>• For half duplex mode, adds 156 millisecond delay between end of transmitted message and enabling receiver</li> <li>• Receiver constantly enabled if not installed</li> </ul>	1-2	156 msec
JP4	2W/4W	<ul style="list-style-type: none"> <li>• Selects 2-wire (half duplex) or 4-wire (full-duplex) operation</li> <li>• Exactly 2 jumpers must be installed</li> </ul>	1-2	2-wire
			3-4	
			<b>5-6</b>	<b>4-wire</b>
			<b>7-8</b>	
JP5	Carrier	<ul style="list-style-type: none"> <li>• Selects switched or constant carrier</li> <li>• Remove jumper for switched carrier</li> </ul>	1-2	<b><i>Removed</i></b>
JP6	900Hz soft carrier turn-off	<ul style="list-style-type: none"> <li>• Installed if 900Hz-carrier turn-off is not required.</li> <li>• Removed if 900Hz-carrier turn-off is required.</li> <li>• Note: Must be installed for V.23 CCITT operation</li> </ul>	<b>1-2</b>	<b><i>Installed</i></b>
JP7	Transmit level range selection	<ul style="list-style-type: none"> <li>• If installed, SW1 settings interpreted as 0 to -15 dB</li> <li>• If removed, SW1 settings interpreted as -16 to -32 dB</li> </ul>	<b>1-2</b>	<b><i>Installed</i></b>
JP9	Reserved	<ul style="list-style-type: none"> <li>• These jumpers are factory installed and must not be altered after shipment.</li> </ul>	<b>3-5</b>	<b><i>Installed</i></b>
			<b>4-6</b>	

### **Power Connection**

View the end of the board with the RJ-11 connector at your left and the three-position power connector at your right. The three power connector pins are as follows:

Location	Pin	Label	Description
Leftmost	1	+	Power Positive
Middle	2	-	Power Negative (return)
Rightmost	3	S	Earth ground (not normally used)

### **RJ-11 Cabling**

The standard RJ-11 jack terminates in 4 spade lugs. The following table contains the cabling options for both 4-wire and 2-wire operation.

RJ-11 Cable	4-wire mode (full duplex)	2-wire mode (half duplex)
Red	Transmit	Transmit/Receive
Green		
Yellow	Receive	Unused
Black		

### **RS-232 Cabling**

The following table itemizes RS-232 pins utilized. Pins not listed are not used.

Pin	Description
1	Frame Ground
2	Transmit Data (TD)
3	Receive Data (RD)
4	Request To Send (RTS)

Pin	Description
5	Clear To Send (CTS)
7	Signal Ground
8	Carrier detect (CD)

### **Common Problems and Solutions**

Description of Problem	Recommended Solution
Messages sent by the ASE modem are not received at the other modem	Make sure that the RTS/CTS time (SW4) on the ASE modem is longer than the carrier detect time on the other modem.
Messages sent by another modem are not received at the ASE modem	Make sure that the RTS/CTS time on the other modem is longer than the "CD On Delay" time (SW3) on the ASE modem.
Frequent communication errors in messages received at non-ASE modem	The ASE modem supports two methods for disabling the carrier, selected by the jumper at JP6. Try the alternate setting.

## Product Codes

Product codes are of the form **SM-MMM-P-K**

<u>MMM</u>	Modem type	202	Bell-202	<u>K</u>	Packaging	B	PC board only
		V23	V.23 CCITT			V	VME chassis mounting bracket
<u>P</u>	Power Option	I	12 to 160 VDC			M	Metal box
		X	5 VDC				

For example:

**SM-202-X-V** specifies a Bell-202 modem with the 5 V power option and VME mounting bracket.

**Diagram: Rack Mount Modem Board**

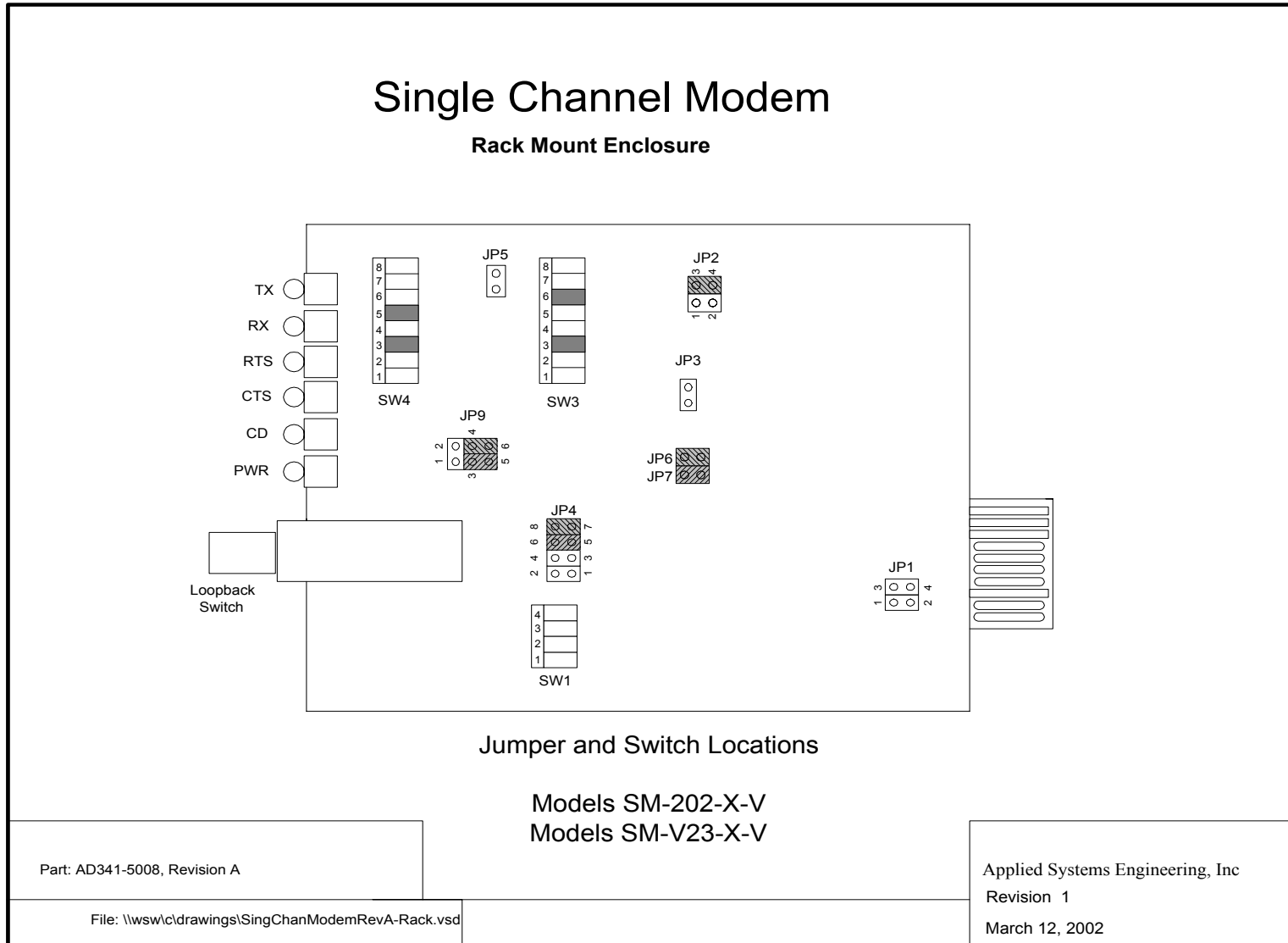

**Diagram: Box Mount Modem Board**

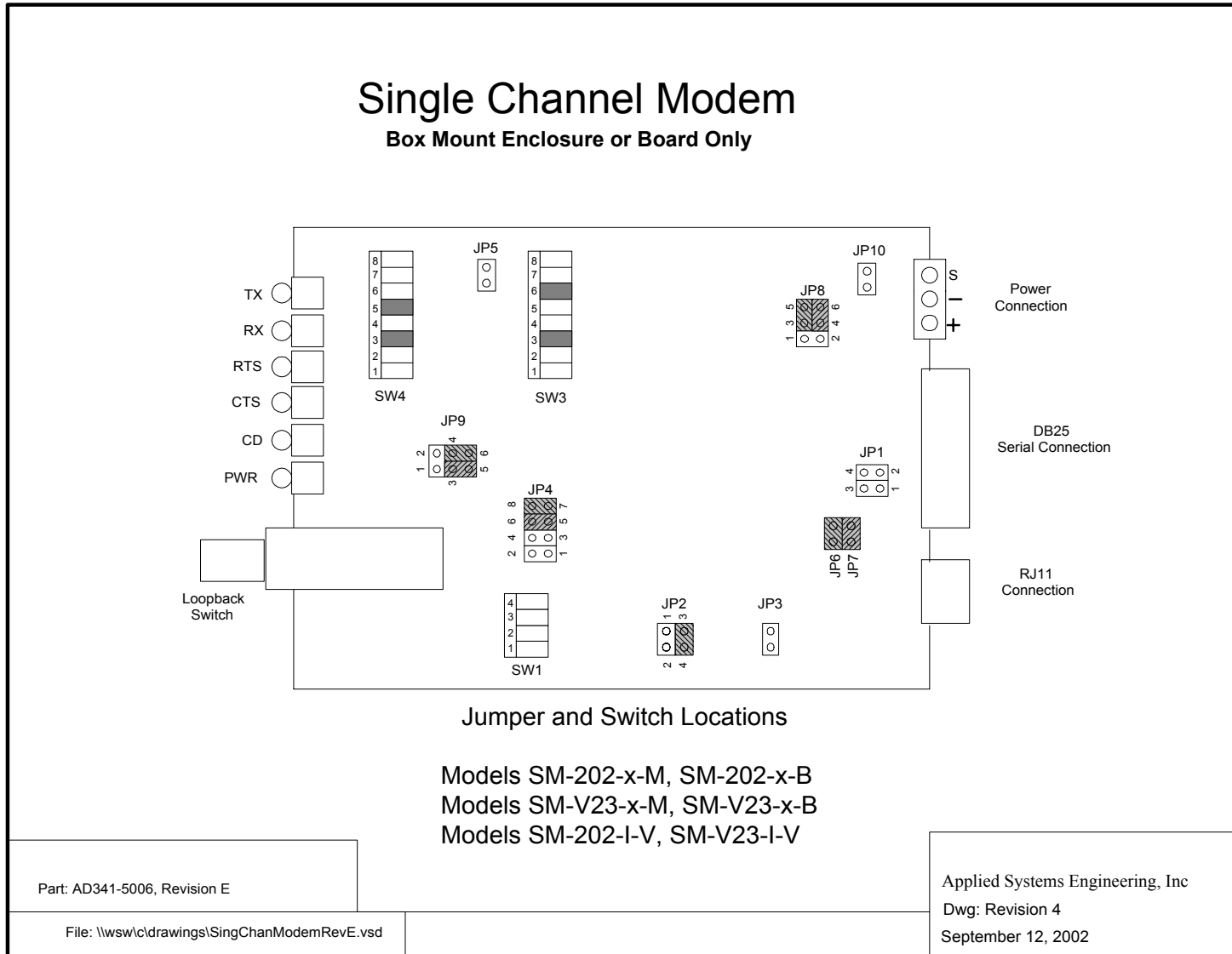

**Diagram: Rack Mount Enclosure Backplane**

